

02/19/2009 CORMIDI DUMPERS VC140

Standard Type 2 Speed Honda Petrol.6.5 hp
 C6.50 RITWIN *Dumper Skip Type*
 Hydraulic dumping
 2 Travel Speed
 Rocking Rollers
 Recoil Starting

Hi-Tip Type 2 Speed Yanmar Diesel 7.5 hp
 C6.50 HIP *Dumper Skip Type*
 Hydraulic dumping
 2 Travel Speed
 Hi Tip
 Rocking Rollers
 Recoil Starting

Specification 500 kg

HondaGX 200 6.5 hp (Petrol)

TRANSMISSION

Type..... *hydrostatic*
 Hydraulic pump *gear pump*
 Flow 2 x 13 l/min
 Hydraulic motors 2 x orbital
 Hydraulic pump *gear pump*
 Flow 1 x 16 l/min
 Max. pressure 175 bar
 Main valve 4 way
 Oil cooler..... *air*
 Tipping system.....*Hydraulic*

TRACKS

Standard track width 180 mm
 Track rollers 3
 Rocking rollers..... *yes*
 Track tensioning *yes*

PERFORMANCE AND DIMENSION

Max. travel speed..... 0-4.0 km/h
 Operating load..... 500 kg
 dry weight..... 300 kg⁴. 290 kg
 Overall length 1550 mm
 Overall width 685 m
 Minimum overall Height..... 1030 mm

Standard Equipment

Grease point on rollers
Rocking Rollers
Heavy duty bottom rollers and idler
Solid steel rocking rollers and idler
Maintenance book

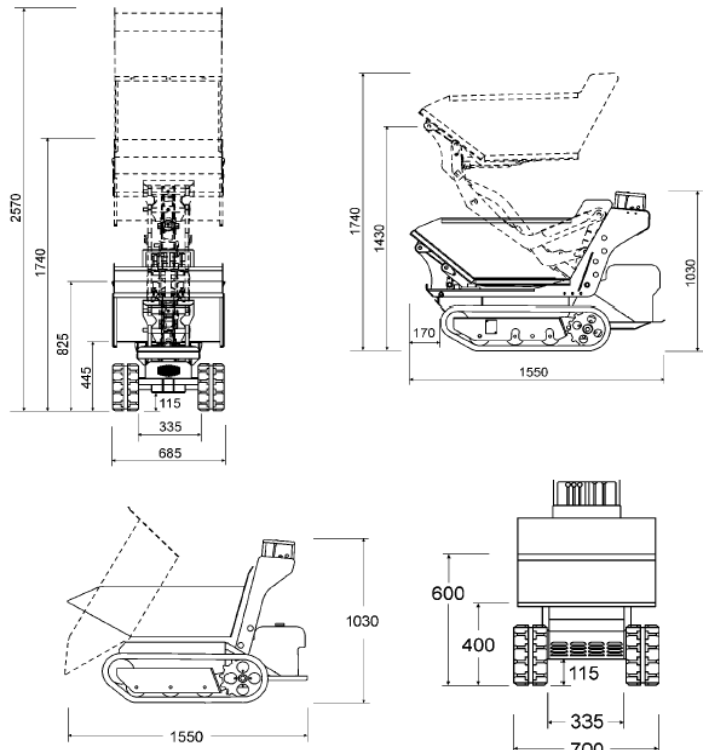

Self loading Type Honda Petrol

C9.65 AC *Dumper Skip Type*
 Hydraulic dumping
 Self loading
 Folding Footplate
 Rocking Rollers
 Recoil Starting

Standard Type Honda Petrol

C9.65 RI *Dumper Skip Type*
 Hydraulic dumping
 Folding Footplate
 Rocking Rollers
 Recoil Starting

Hi-Tip Self Loading Type Honda Petrol

C9.65 HIACW *Dumper Skip Type*
 Front tip bucket -Hyd. remotes
 Hydraulic dumping -Hi-Tip
 Self loading -Folding Footplate
 Rocking Rollers -Recoil Starting

Specification 650 kg

Hi-Tip Type Honda Petrol
 C9.65 HI *Dumper Skip Type*

Hydraulic dumping -Hi-Tip
Folding Footplate -Rocking Rollers
Recoil Starting

Honda Petrol GX 270 9 hp

TRANSMISSION

Type..... hydrostatic
 Hydraulic pump 2 x variable displacement
 Flow 2 x 25.2 l/min
 Hydraulic motors 2 x orbital
 Parking brake mechanical
 Hydraulic pumps gear pump
 Std Flow..... 1 x 13.5 l/min
 Max. pressure 150 bar
 Main valve..... 2 way
 Oil cooler..... air
 Skip tipping system Hydraulic

TRACKS

Standard track width 180 mm
 Track rollers 3
 Rocking rollers..... yes
 Track tensioning si / yes

PERFORMANCE AND DIMENSION

Max. travel speed 0-4.5 km/h
 Operative weight..... 650 kg.
 dry weight 395 kg.
 Overall length 1700 mm .
 Overall width 800 mm .
 Overall Height 1140 mm
 Standard tip skip 1150 x 800 x 350 mm .

Standard Equipment

- Grease point on rollers
- Rocking Rollers
- Heavy duty bottom rollers and idler
- Solid steel rollers and idlers
- Maintance tools
- Maintanance book
- Folding Footplate
- Flexibly mounted engine and footplate
- Auto aligning bearing in all cylinder s
- External output
- Float position on loader
- Pump with variable displacement

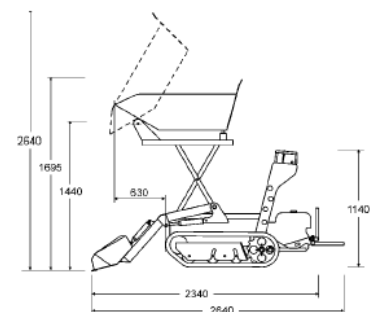
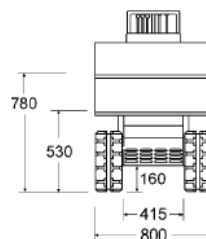
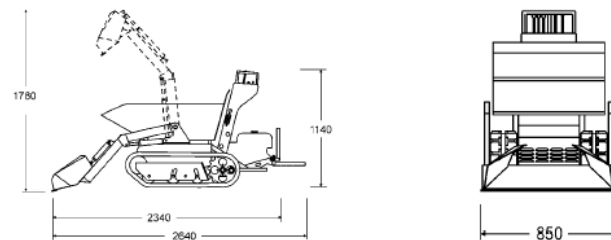

Standard Type Honda Petrol
 C13.80 RI *Dumper Skip Type*
Electric Start **C13.80RIA Ag. Skip**
Hydraulic dumping
Folding Footplate
Rocking Rollers

Self loading Type Yanmar Diesel
 C10.80 AC *Dumper Skip Type*
Electric Start
Hydraulic dumping
Self loading
Folding Footplate
Rocking Rollers

Self loading Type Honda Petrol
 C13.80 ACW *Dumper Skip Type*
Swivel bucket
Electric Start
Folding Footplate
Hydraulic dumping
Self loading
Rocking Rollers
 1° *Extra PTO*

Extra oil cooler
 C5080.05.00 *Drill*^{1 2}
 C5080.08.00 *Auger* Ø 250 mm / *Tools* Ø 250 mm

Specification 800 kg

Honda *Petrol* GX 390 13 hp
 Yanmar *Diesel* 10 hp
 Starter *Electric*

TRANSMISSION

Type *hydrostatic*
Hydraulic pump *2 × variable displacement*
Flow *2 x 32.4 l/min*
Hydraulic motors *2 x orbital*
Parking Brake *mechanical*
Hydraulic pumps *gear pump*
Std Flow *1 x 13.5 l/min*
High Flow *1 x 22 l/min*
Max. pressure *150 bar*
Main valve *2 way / 3 way*³
Oil Cooler *air*
Skip tipping System *Hydraulic*

TRACKS

Standard track width *180 mm*
Track rollers *3*
Rocking rollers *yes*
Track tensioning *yes*

PERFORMANCE AND DIMENSION

Max travel speed *0-4.8 km/h*⁴ *0-6.3 km/h*
Operating load *800 kg*
dry weight *420 kg*² . *520 kg*³
Overall length *1700 mm*² . *2300 mm*³
Overall width *800 mm*² . *850 mm*³
Overall Height *1140 mm*
Standard tip Skip *1150 x 800 x 350 mm*² . *1150 x 680 x 350 mm*³
Agriculture Skip *1100 (1350 max) mm x 800 (1300 max) mm x 250 mm*⁵

² *Standard tip type*
³ *Self loading type*
⁵ *Only for Standard tip type*
⁴ *Diesel type*

Standard Equipment

Grease point on rollers
Rocking Rollers
Heavy duty bottom rollers and idler
Solid steel rollers and idlers

Maintenance tools
 Maintenance book
 Folding Footplate
 Flexibly mounted engine and footp late
 Auto aligning bearing in all cylinder s
 Float position on loader

